

# TROUBLE SHOOTING GUIDE - ZEBRA S4M

95% of all printer problems are solved by following the below procedures. If after following these procedures you are still having issues then we offer one months free phone assistance after installation and outside that period phone assistance will be charged \$125 per hour.

## ➤ Ribbon and Media Loading Procedure

- 1) Open the printhead
- 2) Only if ribbons are used. Install the ribbon and unroll a few feet. Thread the ribbon along the path illustrated in black and wind around the Ribbon Takeup Spindle (A) several times (Fig 1.)

Fig 1. Ribbon Path

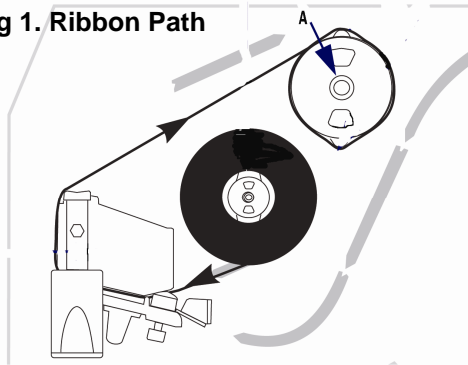
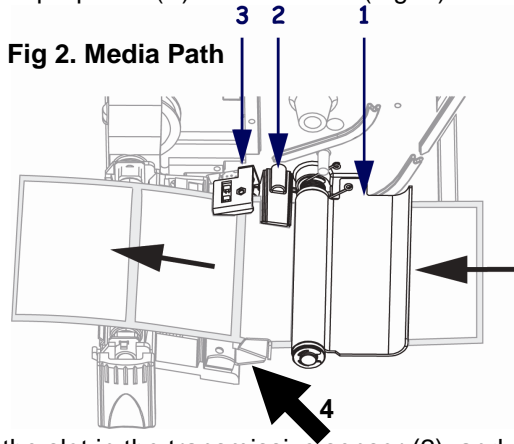

Fig 2. Media Path



- 3) Feed the media under the dancer arm (1), through the slot in the transmissive sensor (2), and under the ribbon sensor (3). Push the media to the back of the transmissive sensor. Slide in the media guide (4) until it just touches the edge of the media. (Fig 2.)
- 4) Close the printhead, press the PAUSE button the printer should now calibrate lining up the label gap or notch on the tear off bar.

**\*\*\*IF YOU STILL GET AN ERROR CHECK THE POSITION OF THE MEDIA SENSOR\*\*\***

## ➤ Adjusting the Media Sensor (Fig 3.)

With the printhead open, move the Sensor Lever (B) across the width of the media until the Reflective Sensor (A) aligns with a gap or notch. Repeat step 4 from above.

**\*\*\*IF YOU STILL GET AN ERROR THEN FACTORY RESET YOUR PRINTER\*\*\***

Fig 3. Sensor Adjustment

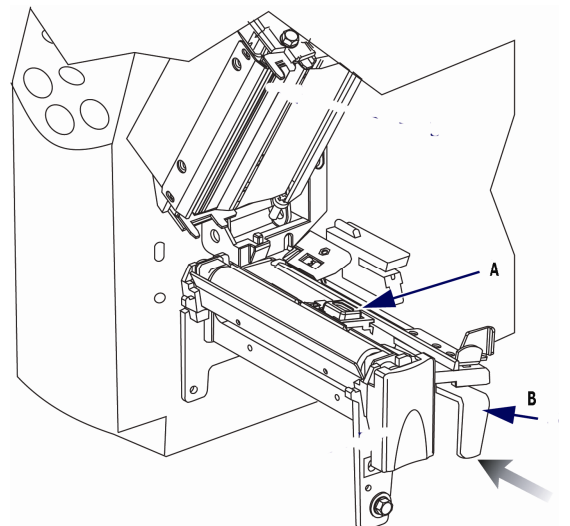

## ➤ Factory Reset Procedure

**NOTE: This will clear any specialty setting you may have setup previously.**

- 1) Press and hold both the Pause Key and Feed Key.
- 2) Turn ON the printer.
- 3) Wait until all the LED's turn on and then the Data LED turns OFF and release the Pause and Feed Keys.
- 4) Press the MENU key, Press the Enter key, the printer will now save the changes.